

SAMPLE TEST QUESTIONS

1. Using 9-bit binary plus a sign bit, the base-10 number +338 is represented by:

- (a) 1011010010
- (b) 0101010010
- (c) 0011010011
- (d) 1011001001

2. Using 7-bit binary plus a sign bit, the 1's complement representation of the binary for -73 is:

- (a) 00110110
- (b) 10110101
- (c) 10110111
- (d) 10110110

3. The logic gate combination on the right represents the Boolean expression:

- (a) $\overline{(A.B) + C}$
- (b) $\overline{A.(B + C)}$
- (c) $(A.B) \oplus C$
- (d) $A . (B \oplus C)$

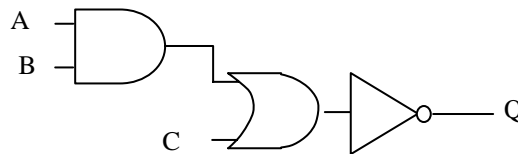

4. Select the truth table which corresponds to the Boolean expression $\overline{(A + B)}$.:

(a)

A	B	Q
0	0	0
0	1	1
1	0	1
1	1	0

(b)

A	B	Q
0	0	1
0	1	0
1	0	0
1	1	1

(c)

A	B	Q
0	0	1
0	1	0
1	0	0
1	1	0

(d)

A	B	Q
0	0	0
0	1	0
1	0	0
1	1	1

5. Use 2's complement addition, representing numbers with 7-bits plus a sign bit, to perform the subtraction $76 - 119$.

6. The diagram on the right illustrates the use of a transistor as a switch in an electrical circuit (i.e. the use of the gate voltage V_{gate} applied to the transistor to control the output voltage V_{out} . Explain briefly how this is done and why using a transistor as a switch is preferable to having a mechanical switch.

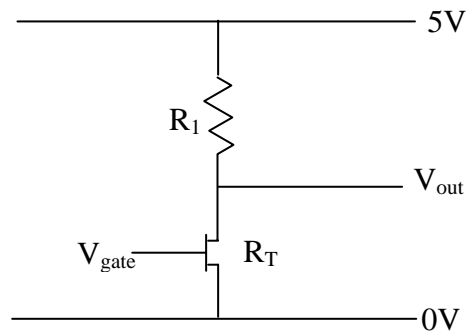

7. Explain briefly the operation of the combinational logic circuit shown below.

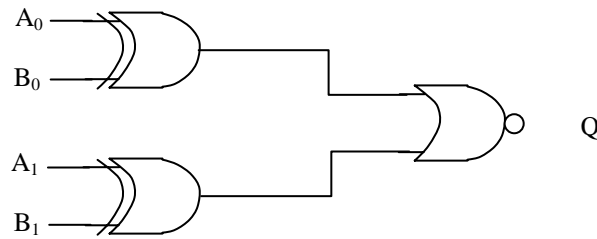

8. Design a logic circuit whose output is HIGH whenever A and B are both HIGH as long as C and D are either both HIGH or both LOW.