

Introduction to Microprocessors

The 8051 Instruction Set

8051 Instruction Set

- ◆ Introduction
- ◆ 8051 architecture and memory organization review
- ◆ Addressing Modes
 - Register addressing
 - Direct addressing
 - Indirect addressing
 - Immediate constant addressing
 - Relative addressing
 - Absolute addressing
 - Long addressing
 - Indexed addressing
- ◆ Instruction Types
 - Arithmetic operations
 - Logical operations
 - Data transfer instructions
 - Boolean variable instructions
 - Program branching instructions

Introduction

- ◆ A computer instruction is made up of an operation code (op-code) followed by either zero, one or two bytes of operands
- ◆ The op-code identifies the type of operation to be performed while the operands identify the source and destination of the data
- ◆ The operand can be:
 - The data value itself
 - A CPU register
 - A memory location
 - An I/O port
- ◆ If the instruction is associated with more than one operand, the format is always:

Instruction

Destination, Source

8051 Architecture Review

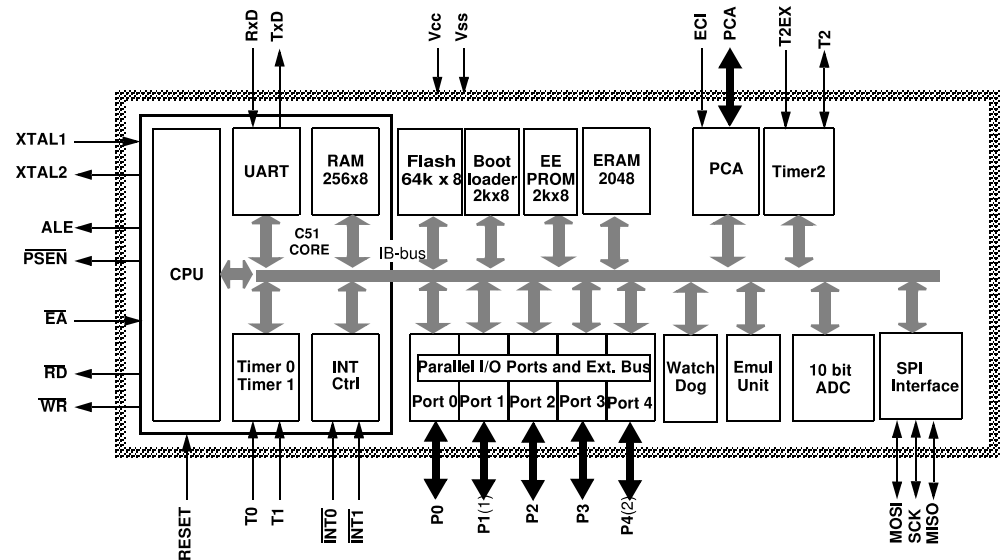
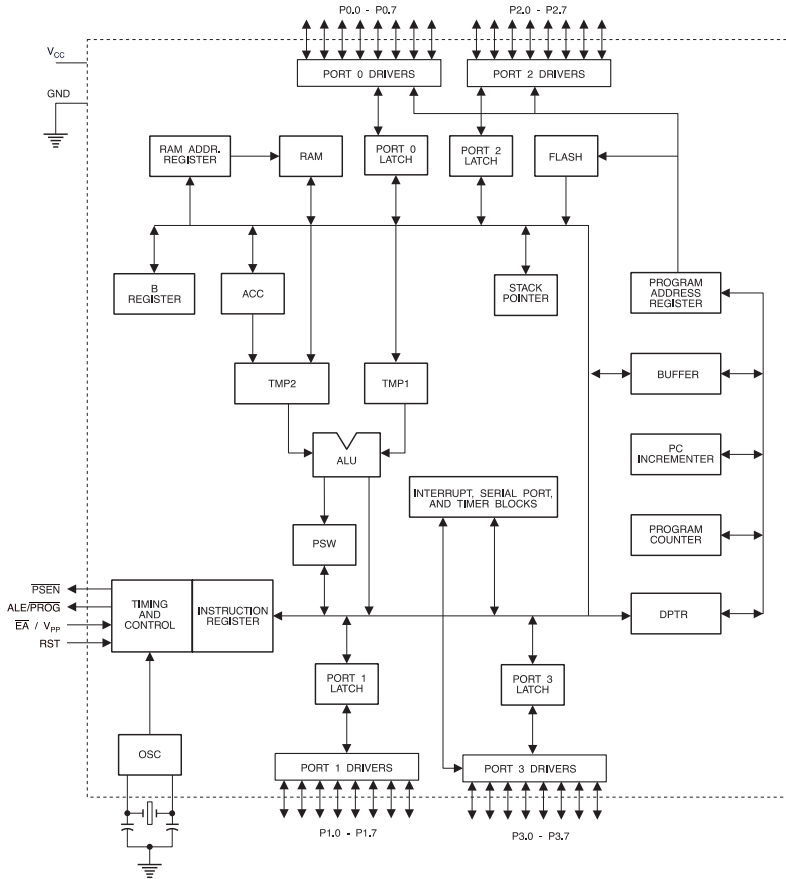

8051 Data Memory (RAM)

- ◆ Internal Data Memory space is divided into three sections
 - Lower 128
 - Upper 128
 - Special function register (SFR)
- ◆ There are 384 bytes of memory space physically, though the Upper 128 and SFRs share the same addresses from location 80H to FFH.
- ◆ Appropriate instructions should be used to access each memory block

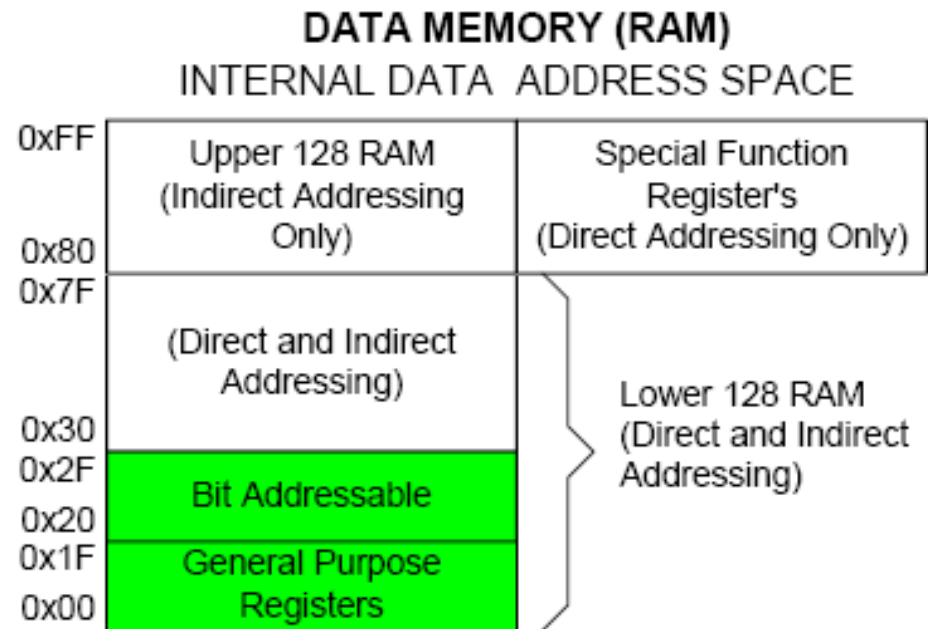

Lower 128—Register Banks and RAM

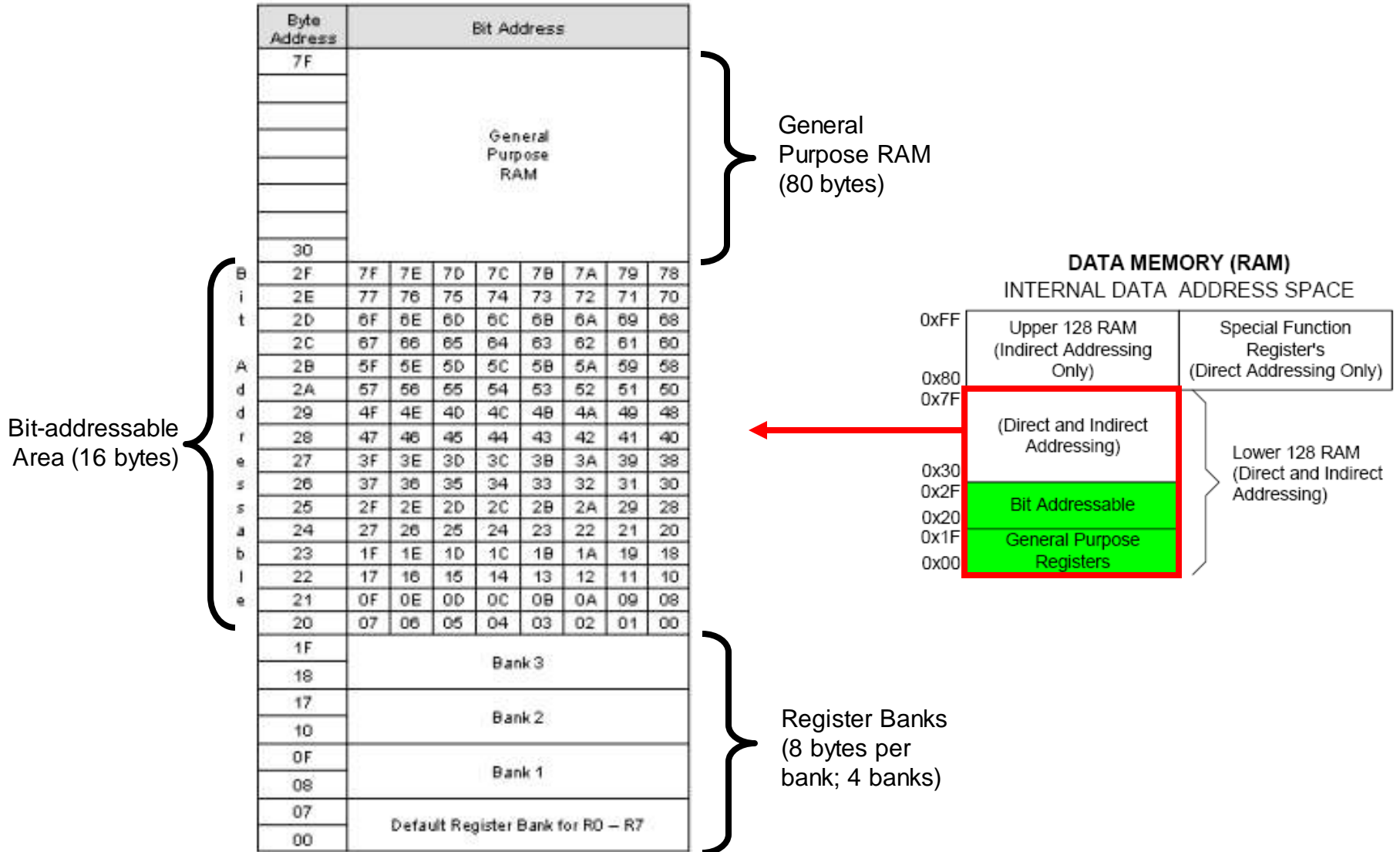

Special Function Registers (SFRs)

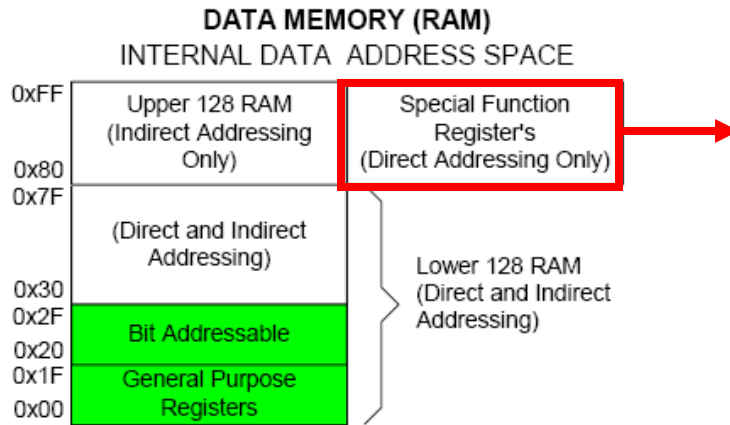

Byte Address	Bit Address								
FF									
F0	F7	F6	F5	F4	F3	F2	F1	F0	B
E0	E7	E6	E5	E4	E3	E2	E1	E0	ACC
D0	D7	D6	D5	D4	D3	D2	-	D0	PSW
B8	-	-	-	BC	BB	BA	B9	B6	IP
B0	B7	B6	B5	B4	B3	B2	B1	B0	P3
A8	AF	-	-	AC	AB	AA	A9	A8	IE
A0	A7	A6	A5	A4	A3	A2	A1	A0	P2
99	Not bit-addressable								SBUF
98	9F	9E	9D	9C	9B	9A	99	98	SCON
90	97	96	95	94	93	92	91	90	P1
8D	Not bit-addressable								TH1
8C	Not bit-addressable								TH0
8B	Not bit-addressable								TL1
8A	Not bit-addressable								TL0
89	Not bit-addressable								TMOD
88	8F	8E	8D	8C	8B	8A	89	88	TCON
87	Not bit-addressable								PCON
83	Not bit-addressable								DPH
82	Not bit-addressable								DPL
81	Not bit-addressable								SP
80	87	86	85	84	83	82	81	80	P0

- ◆ SFRs provide control and data exchange with the microcontroller's resources and peripheral (not all are shown here, only the ones common to the core)
- ◆ Registers which have their byte addresses ending with 0H or 8H are *byte-* as well as *bit-* addressable
- ◆ Some registers are not bit-addressable. These include the stack pointer (SP) and data pointer register (DPTR)

AT89C51AC3 Special Function Registers

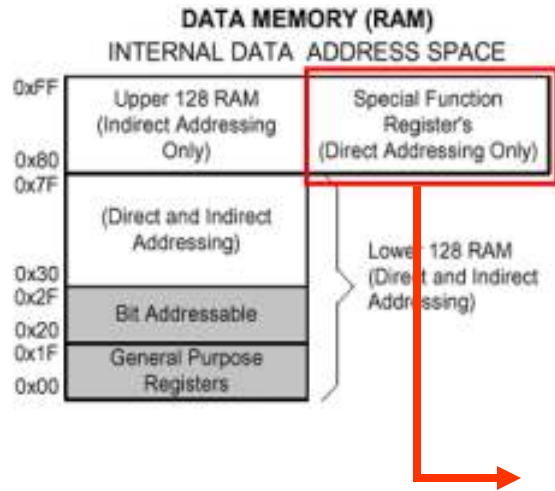

Table 1. SFR Mapping

	0/8 ⁽²⁾	1/9	2/A	3/B	4/C	5/D	6/E	7/F	
F8h	IPL1 xxxx x0x0	CH 0000 0000	CCAP0H 0000 0000	CCAP1H 0000 0000	CCAP2H 0000 0000	CCAP3H 0000 0000	CCAP4H 0000 0000		FFh
F0h	B 0000 0000		ADCLK xxx0 0000	ADCON x000 0000	ADDL 0000 0000	ADDH 0000 0000	ADCF 0000 0000	IPH1 xxxx x0x0	F7h
E8h	IEN1 xxxx x0x0	CL 0000 0000	CCAP0L 0000 0000	CCAP1L 0000 0000	CCAP2L 0000 0000	CCAP3L 0000 0000	CCAP4L 0000 0000		EFh
E0h	ACC 0000 0000								E7h
D8h	CCON 0000 0000	CMOD 00xx x000	CCAPM0 x000 0000	CCAPM1 x000 0000	CCAPM2 x000 0000	CCAPM3 x000 0000	CCAPM4 x000 0000		DFh
D0h	PSW 0000 0000	FCON 0000 0000	EECON xxxx xx00	FSTA xxxx xx00	SPCON 0001 0100	SPSCR 0000 0000	SPDAT xxxx xxxx		D7h
C8h	T2CON 0000 0000	T2MOD xxxx xx00	RCAP2L 0000 0000	RCAP2H 0000 0000	TL2 0000 0000	TH2 0000 0000			CFh
C0h	P4 xxx1 1111								C7h
B8h	IPL0 x000 0000	SADEN 0000 0000							BFh
B0h	P3 1111 1111							IPH0 x000 0000	B7h
A8h	IEN0 0000 0000	SADDR 0000 0000							AFh
A0h	P2 1111 1111		AUXR1 xxxx 00x0				WDTRST 1111 1111	WDTPRG xxxx x000	A7h
98h	SCON 0000 0000	SBUF 0000 0000						CKCON1 xxxx xxx0	9Fh
90h	P1 1111 1111								97h
88h	TCON 0000 0000	TMOD 0000 0000	TL0 0000 0000	TL1 0000 0000	TH0 0000 0000	TH1 0000 0000	AUXR x001 0100	CKCON0 x00 0000	8Fh
80h	P0 1111 1111	SP 0000 0111	DPL 0000 0000	DPH 0000 0000				PCON 00x1 0000	87h
	0/8 ⁽²⁾	1/9	2/A	3/B	4/C	5/D	6/E	7/F	

Program Memory

- ◆ FLASH memory
 - Can be reprogrammed in-circuit
 - Provides non-volatile data storage
 - Allows field upgrades of the 8051 firmware
- ◆ The AT89C51AC3's program memory consists of 65536 bytes of FLASH

Program/Code Memory Organization

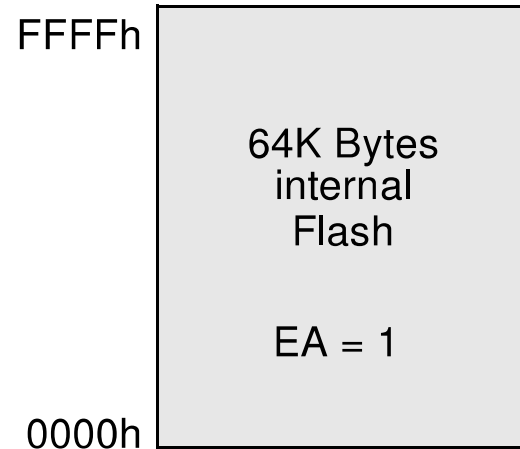

Boot Program Memory

Flash Memory Architecture with ENBOOT=1 (boot mode)

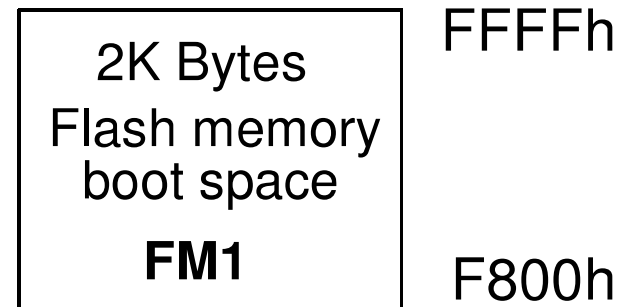
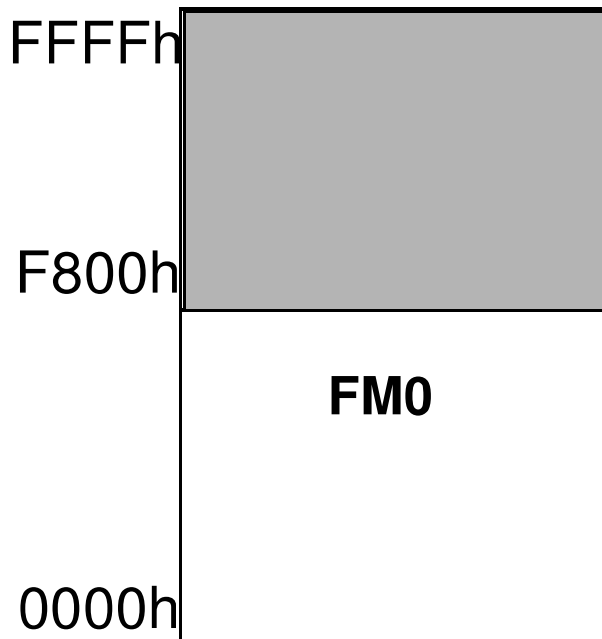

FM1 mapped between FFFFh and F800h when bit ENBOOT is set in AUXR1 register

 Memory space not accessible

Addressing Modes

- ◆ Eight modes of addressing are available with the 8051
- ◆ The different addressing modes determine how the operand byte is selected

Addressing Modes	Instruction
Register	MOV A, B
Direct	MOV 30H,A
Indirect	ADD A,@R0
Immediate Constant	ADD A,#80H
Relative*	SJMP AHEAD
Absolute*	AJMP BACK
Long*	LJMP FAR_AHEAD
Indexed	MOVC A,@A+PC

* Related to program branching instructions

Register Addressing

- ◆ The register addressing instruction involves information transfer between registers

- ◆ *Example:*

MOV R0, A

- ◆ The instruction transfers the accumulator content into the R0 register. The register bank (Bank 0, 1, 2 or 3) must be specified prior to this instruction.

Lower 128—Register Banks and RAM

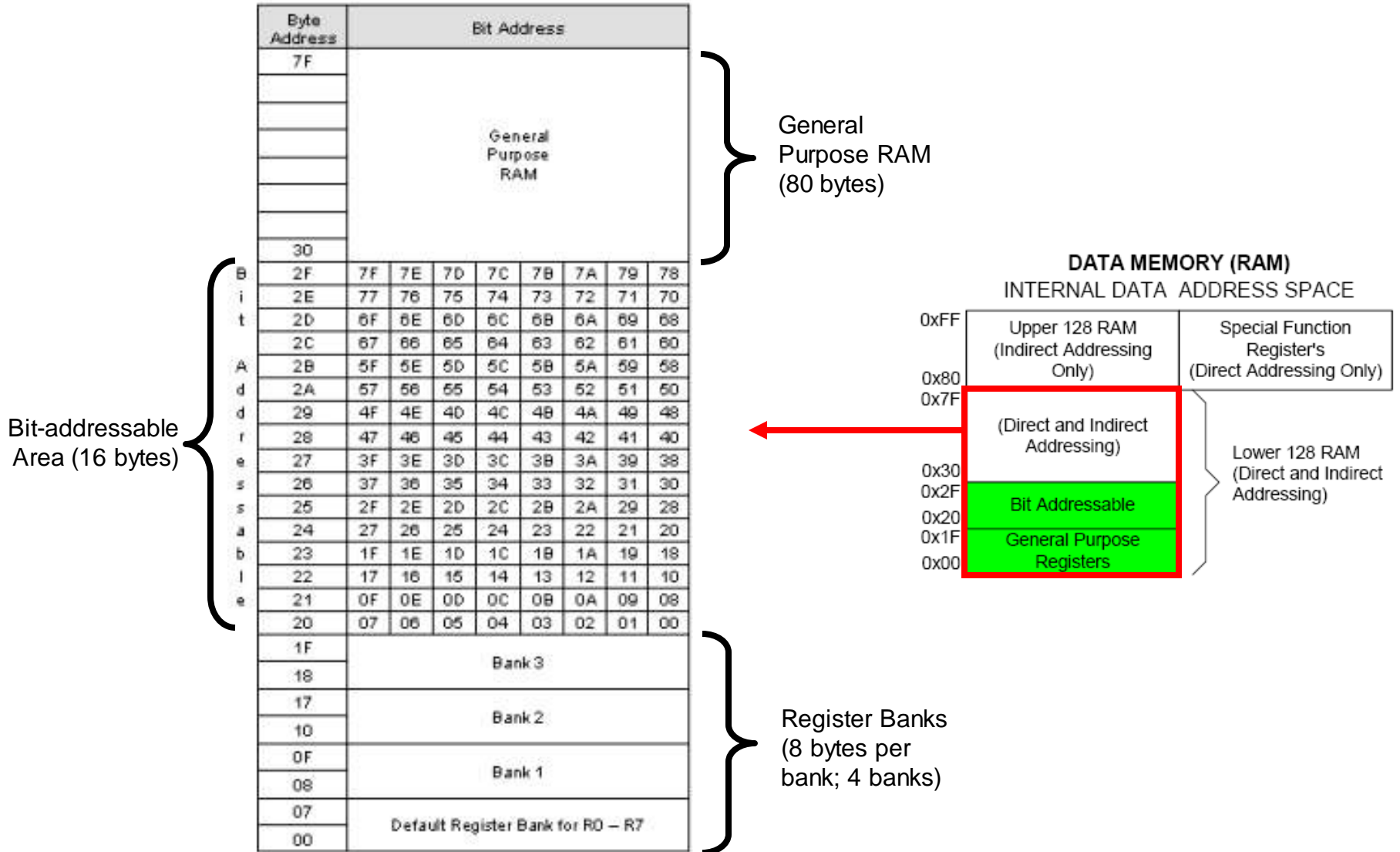

Direct Addressing

- ◆ This mode allows you to specify the operand by giving its actual memory address (typically specified in hexadecimal format) or by giving its abbreviated name (e.g. P3)

Note: Abbreviated SFR names are often defined in a header file

- ◆ *Example:*

```
MOV    A, P3      ;Transfer the contents of
                  ;Port 3 to the accumulator

MOV    A, 020H    ;Transfer the contents of RAM
                  ;location 20H to the accumulator
```

Indirect Addressing

- ◆ This mode uses a pointer to hold the effective address of the operand
- ◆ Only registers R0, R1 and DPTR can be used as the pointer registers
- ◆ The R0 and R1 registers can hold an 8-bit address, whereas DPTR can hold a 16-bit address
- ◆ **Examples:**

```
MOV    @R0,A    ;Store the content of  
           ;accumulator into the memory  
           ;location pointed to by  
           ;register R0. R0 could have an  
           ;8-bit address, such as 60H.
```

```
MOVX   A,@DPTR  ;Transfer the contents from  
           ;the memory location  
           ;pointed to by DPTR into the  
           ;accumulator. DPTR could have a  
           ;16-bit address, such as 1234H.
```

Immediate Constant Addressing

- ◆ This mode of addressing uses either an 8- or 16-bit constant value as the source operand
- ◆ This constant is specified in the instruction, rather than in a register or a memory location
- ◆ The destination register should hold the same data size which is specified by the source operand

- ◆ *Examples:*

```
ADD A,#030H ;Add 8-bit value of 30H to  
;the accumulator register  
;(which is an 8-bit register).
```

```
MOV DPTR,#0FE00H ;Move 16-bit data constant  
;FE00H into the 16-bit Data  
;Pointer Register.
```

Relative Addressing

- ◆ This mode of addressing is used with some type of jump instructions, like SJMP (short jump) and conditional jumps like JNZ
- ◆ These instructions transfer control from one part of a program to another
- ◆ The destination address must be within -128 and +127 bytes from the current instruction address because an 8-bit offset is used ($2^8 = 256$)
- ◆ *Example:*

```
GoBack:   DEC     A           ;Decrement A
          JNZ    GoBack ;If A is not zero, loop back
```

Absolute Addressing

- ◆ Two instructions associated with this mode of addressing are ACALL and AJMP instructions
- ◆ These are 2-byte instructions where the 11-bit absolute address is specified as the operand
- ◆ The upper 5 bits of the 16-bit PC address are not modified. The lower 11 bits are loaded from this instruction. So, the branch address must be within the current 2K byte page of program memory ($2^{11} = 2048$)
- ◆ *Example:*

```
ACALL    PORT_INIT    ;PORT_INIT should be  
                    ;located within 2k bytes.
```

```
PORT_INIT: MOV      P0, #0FH    ;PORT_INIT subroutine
```

Long Addressing

- ◆ This mode of addressing is used with the LCALL and LJMP instructions
- ◆ It is a 3-byte instruction and the last 2 bytes specify a 16-bit destination location where the program branches
- ◆ It allows use of the full 64 K code space
- ◆ The program will always branch to the same location no matter where the program was previously
- ◆ *Example:*

```
    LCALL TIMER_INIT      ;TIMER_INIT address (16-bits  
                          ;long) is specified as the  
                          ;operand; In C, this will be a  
                          ;function call: Timer_Init().
```

```
TIMER_INIT: ORL TMOD,#01H ;TIMER_INIT subroutine
```

Indexed Addressing

- ◆ The Indexed addressing is useful when there is a need to retrieve data from a look-up table
- ◆ A 16-bit register (data pointer) holds the base address and the accumulator holds an 8-bit displacement or index value
- ◆ The sum of these two registers forms the effective address for a JMP or MOVC instruction

- ◆ *Example:*

```
MOV      A,#08H           ;Offset from table start
MOV      DPTR,#01F00H     ;Table start address
MOVC     A,@A+DPTR        ;Gets target value from the table
                           ;start address + offset and puts it
                           ;in A.
```

- ◆ After the execution of the above instructions, the program will branch to address 1F08H (1F00H+08H) and transfer into the accumulator the data byte retrieved from that location (from the look-up table)

Instruction Types

- ◆ The 8051 instructions are divided into five functional groups:
 - Arithmetic operations
 - Logical operations
 - Data transfer operations
 - Boolean variable operations
 - Program branching operations

Arithmetic Operations

- ◆ With arithmetic instructions, the 8051 CPU has no special knowledge of the data format (e.g. signed binary, unsigned binary, binary coded decimal, ASCII, etc.)
- ◆ The appropriate status bits in the PSW are set when specific conditions are met, which allows the user software to manage the different data formats

Mnemonic	Description
ADD A, Rn	$A = A + [Rn]$
ADD A, direct	$A = A + [\text{direct memory}]$
ADD A, @Ri	$A = A + [\text{memory pointed to by Ri}]$
ADD A, #data	$A = A + \text{immediate data}$
ADDC A, Rn	$A = A + [Rn] + CY$
ADDC A, direct	$A = A + [\text{direct memory}] + CY$
ADDC A, @Ri	$A = A + [\text{memory pointed to by Ri}] + CY$
ADDC A, #data	$A = A + \text{immediate data} + CY$
SUBB A, Rn	$A = A - [Rn] - CY$
SUBB A, direct	$A = A - [\text{direct memory}] - CY$
SUBB A, @Ri	$A = A - [@Ri] - CY$
SUBB A, #data	$A = A - \text{immediate data} - CY$
INC A	$A = A + 1$
INC Rn	$[Rn] = [Rn] + 1$
INC direct	$[\text{direct}] = [\text{direct}] + 1$
INC @Ri	$[@Ri] = [@Ri] + 1$
DEC A	$A = A - 1$
DEC Rn	$[Rn] = [Rn] - 1$
DEC direct	$[\text{direct}] = [\text{direct}] - 1$
DEC @Ri	$[@Ri] = [@Ri] - 1$
MUL AB	Multiply A & B
DIV AB	Divide A by B
DA A	Decimal adjust A

- ◆ [$@Ri$] implies contents of memory location pointed to by R0 or R1
- ◆ Rn refers to registers R0-R7 of the currently selected register bank

Logical Operations

- ◆ Logical instructions perform Boolean operations (AND, OR, XOR, and NOT) on data bytes on a *bit-by-bit* basis

- ◆ Examples:

ANL A, #02H ;Mask bit 1

ORL TCON, A ;TCON=TCON-OR-A

Mnemonic	Description
ANL A, Rn	A = A & [Rn]
ANL A, direct	A = A & [direct memory]
ANL A, @Ri	A = A & [memory pointed to by Ri]
ANL A, #data	A = A & immediate data
ANL direct, A	[direct] = [direct] & A
ANL direct, #data	[direct] = [direct] & immediate data
ORL A, Rn	A = A OR [Rn]
ORL A, direct	A = A OR [direct]
ORL A, @Ri	A = A OR [@Ri]
ORL A, #data	A = A OR immediate data
ORL direct, A	[direct] = [direct] OR A
ORL direct, #data	[direct] = [direct] OR immediate data
XRL A, Rn	A = A XOR [Rn]
XRL A, direct	A = A XOR [direct memory]
XRL A, @Ri	A = A XOR [@Ri]
XRL A, #data	A = A XOR immediate data
XRL direct, A	[direct] = [direct] XOR A
XRL direct, #data	[direct] = [direct] XOR immediate data
CLR A	Clear A
CPL A	Complement A
RL A	Rotate A left
RLC A	Rotate A left (through C)
RR A	Rotate A right
RRC A	Rotate A right (through C)
SWAP A	Swap nibbles

Data Transfer Instructions

- ◆ Data transfer instructions can be used to transfer data between an internal RAM location and an SFR location without going through the accumulator
- ◆ It is also possible to transfer data between the internal and external RAM by using indirect addressing
- ◆ The upper 128 bytes of data RAM are accessed only by indirect addressing and the SFRs are accessed only by direct addressing

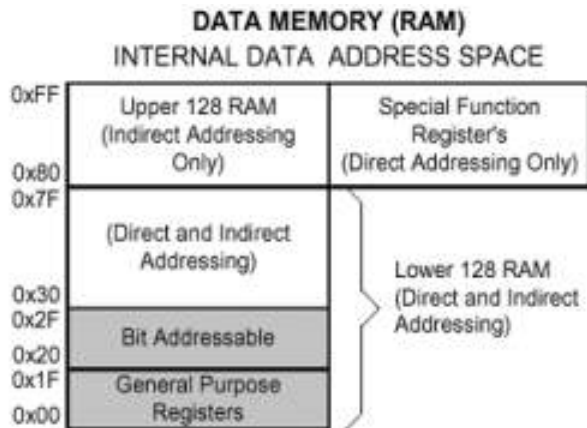

Mnemonic	Description
MOV @Ri, direct	[@Ri] = [direct]
MOV @Ri, #data	[@Ri] = immediate data
MOV DPTR, #data 16	[DPTR] = immediate data
MOVC A, @A+DPTR	A = Code byte from [@A+DPTR]
MOVC A, @A+PC	A = Code byte from [@A+PC]
MOVX A, @Ri	A = Data byte from external ram [@Ri]
MOVX A, @DPTR	A = Data byte from external ram [@DPTR]
MOVX @Ri, A	External[@Ri] = A
MOVX @DPTR, A	External[@DPTR] = A
PUSH direct	Push into stack
POP direct	Pop from stack
XCH A, Rn	A = [Rn], [Rn] = A
XCH A, direct	A = [direct], [direct] = A
XCH A, @Ri	A = [@Rn], [@Rn] = A
XCHD A, @Ri	Exchange low order digits

Boolean Variable Instructions

- ◆ The 8051 processor can perform single bit operations
- ◆ The operations include *set*, *clear*, *and*, *or* and *complement* instructions
- ◆ Also included are bit-level moves or conditional jump instructions
- ◆ All bit accesses use direct addressing

- ◆ **Examples:**

```
SETB TR0 ;Start Timer0.
```

```
POLL: JNB TR0, POLL ;Wait  
till timer overflows.
```

Mnemonic	Description
CLR C	Clear C
CLR bit	Clear direct bit
SETB C	Set C
SETB bit	Set direct bit
CPL C	Complement c
CPL bit	Complement direct bit
ANL C,bit	AND bit with C
ANL C,/bit	AND NOT bit with C
ORL C,bit	OR bit with C
ORL C,/bit	OR NOT bit with C
MOV C,bit	MOV bit to C
MOV bit,C	MOV C to bit
JC rel	Jump if C set
JNC rel	Jump if C not set
JB bit,rel	Jump if specified bit set
JNB bit,rel	Jump if specified bit not set
JBC bit,rel	if specified bit set then clear it and jump

Program Branching Instructions

- ◆ Program branching instructions are used to control the flow of program execution
- ◆ Some instructions provide decision making capabilities before transferring control to other parts of the program (conditional branches).

Mnemonic	Description
ACALL addr11	Absolute subroutine call
LCALL addr16	Long subroutine call
RET	Return from subroutine
RETI	Return from interrupt
AJMP addr11	Absolute jump
LJMP addr16	Long jump
SJMP rel	Short jump
JMP @A+DPTR	Jump indirect
JZ rel	Jump if A=0
JNZ rel	Jump if A NOT=0
CJNE A,direct,rel	Compare and Jump if Not Equal
CJNE A,#data,rel	
CJNE Rn,#data,rel	
CJNE @Ri,#data,rel	
DJNZ Rn,rel	Decrement and Jump if Not Zero
DJNZ direct,rel	
NOP	No Operation

Appendix

8051 Instruction

Arithmetic Operations

- ◆ [$@R_i$] implies contents of memory location pointed to by R_0 or R_1
- ◆ R_n refers to registers R_0 - R_7 of the currently selected register bank

Mnemonic	Description
ADD A, Rn	$A = A + [R_n]$
ADD A, direct	$A = A + [\text{direct memory}]$
ADD A, @Ri	$A = A + [\text{memory pointed to by } R_i]$
ADD A, #data	$A = A + \text{immediate data}$
ADDC A, Rn	$A = A + [R_n] + CY$
ADDC A, direct	$A = A + [\text{direct memory}] + CY$
ADDC A, @Ri	$A = A + [\text{memory pointed to by } R_i] + CY$
ADDC A, #data	$A = A + \text{immediate data} + CY$
SUBB A, Rn	$A = A - [R_n] - CY$
SUBB A, direct	$A = A - [\text{direct memory}] - CY$
SUBB A, @Ri	$A = A - [@R_i] - CY$
SUBB A, #data	$A = A - \text{immediate data} - CY$
INC A	$A = A + 1$
INC Rn	$[R_n] = [R_n] + 1$
INC direct	$[\text{direct}] = [\text{direct}] + 1$
INC @Ri	$[@R_i] = [@R_i] + 1$
DEC A	$A = A - 1$
DEC Rn	$[R_n] = [R_n] - 1$
DEC direct	$[\text{direct}] = [\text{direct}] - 1$
DEC @Ri	$[@R_i] = [@R_i] - 1$
MUL AB	Multiply A & B
DIV AB	Divide A by B
DA A	Decimal adjust A

ADD A,<source-byte> ADDC A,<source-byte>

- ◆ ADD adds the data byte specified by the source operand to the accumulator, leaving the result in the accumulator
- ◆ ADDC adds the data byte specified by the source operand, the carry flag and the accumulator contents, leaving the result in the accumulator
- ◆ Operation of both the instructions, ADD and ADDC, can affect the carry flag (CY), auxiliary carry flag (AC) and the overflow flag (OV)
 - CY=1 If there is a carryout from bit 7; cleared otherwise
 - AC =1 If there is a carryout from the lower 4-bit of A i.e. from bit 3; cleared otherwise
 - OV=1 If the signed result cannot be expressed within the number of bits in the destination operand; cleared otherwise

SUBB A,<source-byte>

- ◆ SUBB subtracts the specified data byte and the carry flag together from the accumulator, leaving the result in the accumulator

CY=1 If a borrow is needed for bit 7; cleared otherwise

AC =1 If a borrow is needed for bit 3, cleared otherwise

OV=1 If a borrow is needed into bit 6, but not into bit 7, or into bit 7, but not into bit 6.

- ◆ *Example:*

The accumulator holds 0C1H (11000001B), Register1 holds 40H (01000000B) and the CY=1. The instruction,

SUBB A, R1

gives the value 70H (01110000B) in the accumulator, with the CY=0 and AC=0 but OV=1

INC <byte>

- ◆ Increments the data variable by 1. The instruction is used in register, direct or register direct addressing modes

- ◆ *Example:*

```
INC    6FH
```

If the internal RAM location 6FH contains 30H, then the instruction increments this value, leaving 31H in location 6FH

- ◆ *Example:*

```
MOV    R1, #5E
```

```
INC    R1
```

```
INC    @R1
```

- ◆ If R1=5E (01011110) and internal RAM location 5FH contains 20H, the instructions will result in R1=5FH and internal RAM location 5FH to increment by one to 21H

DEC <byte>

- ◆ The data variable is decremented by 1
- ◆ The instruction is used in accumulator, register, direct or register direct addressing modes
- ◆ A data of value 00H underflows to FFH after the operation
- ◆ No flags are affected

INC DPTR

- ◆ Increments the 16-bit data pointer by 1
- ◆ DPTR is the only 16-bit register that can be incremented
- ◆ The instruction adds one to the contents of DPTR directly

MUL AB

- ◆ Multiplies A & B and the 16-bit result stored in [B15-8], [A7-0]
- ◆ Multiplies the unsigned 8-bit integers in the accumulator and the B register
- ◆ The **Low** order byte of the 16-bit product will go to the accumulator and the **High** order byte will go to the B register
- ◆ If the product is greater than 255 (FFH), the overflow flag is set; otherwise it is cleared. The carry flag is always cleared.
- ◆ If ACC=85 (55H) and B=23 (17H), the instruction gives the product 1955 (07A3H), so B is now 07H and the accumulator is A3H. The overflow flag is set and the carry flag is cleared.

DIV AB

- ◆ Divides A by B
- ◆ The integer part of the quotient is stored in A and the remainder goes to the B register
- ◆ If ACC=90 (5AH) and B=05(05H), the instruction leaves 18 (12H) in ACC and the value 00 (00H) in B, since $90/5 = 18$ (quotient) and 00 (remainder)
- ◆ Carry and OV are both cleared
- ◆ *If B contains 00H before the division operation, then the values stored in ACC and B are undefined and an overflow flag is set. The carry flag is cleared.*

DA A

- ◆ This is a decimal adjust instruction
- ◆ It adjusts the 8-bit value in ACC resulting from operations like ADD or ADDC and produces two 4-bit digits (in packed Binary Coded Decimal (BCD) format)
- ◆ Effectively, this instruction performs the decimal conversion by adding 00H, 06H, 60H or 66H to the accumulator, depending on the initial value of ACC and PSW
- ◆ If ACC bits A3-0 are greater than 9 (xxxx1010-xxxx1111), or if AC=1, then a value 6 is added to the accumulator to produce a correct BCD digit in the lower order nibble
- ◆ If CY=1, because the high order bits A7-4 is now exceeding 9 (1010xxxx-1111xxxx), then these high order bits will be increased by 6 to produce a correct proper BCD in the high order nibble but not clear the carry

Logical Operations

Mnemonic	Description
ANL A, Rn	$A = A \& [Rn]$
ANL A, direct	$A = A \& [\text{direct memory}]$
ANL A, @Ri	$A = A \& [\text{memory pointed to by Ri}]$
ANL A, #data	$A = A \& \text{immediate data}$
ANL direct, A	$[\text{direct}] = [\text{direct}] \& A$
ANL direct, #data	$[\text{direct}] = [\text{direct}] \& \text{immediate data}$
ORL A, Rn	$A = A \text{ OR } [Rn]$
ORL A, direct	$A = A \text{ OR } [\text{direct}]$
ORL A, @Ri	$A = A \text{ OR } [@Ri]$
ORL A, #data	$A = A \text{ OR immediate data}$
ORL direct, A	$[\text{direct}] = [\text{direct}] \text{ OR } A$
ORL direct, #data	$[\text{direct}] = [\text{direct}] \text{ OR immediate data}$
XRL A, Rn	$A = A \text{ XOR } [Rn]$
XRL A, direct	$A = A \text{ XOR } [\text{direct memory}]$
XRL A, @Ri	$A = A \text{ XOR } [@Ri]$
XRL A, #data	$A = A \text{ XOR immediate data}$
XRL direct, A	$[\text{direct}] = [\text{direct}] \text{ XOR } A$
XRL direct, #data	$[\text{direct}] = [\text{direct}] \text{ XOR immediate data}$
CLR A	Clear A
CPL A	Complement A
RL A	Rotate A left
RLC A	Rotate A left (through C)
RR A	Rotate A right
RRC A	Rotate A right (through C)
SWAP A	Swap nibbles

- ◆ Logical instructions perform Boolean operations (AND, OR, XOR, and NOT) on data bytes on a **bit-by-bit** basis

ANL <dest-byte>,<source-byte>

- ◆ This instruction performs the logical AND operation on the source and destination operands and stores the result in the destination variable

- ◆ No flags are affected

- ◆ *Example:*

ANL A,R2

If ACC=D3H (11010011) and R2=75H (01110101), the result of the instruction is ACC=51H (01010001)

- ◆ The following instruction is also useful when there is a need to mask a byte

- ◆ *Example:*

ANL P1,#10111001B

ORL <dest-byte>, <source-byte>

- ◆ This instruction performs the logical OR operation on the source and destination operands and stores the result in the destination variable

- ◆ No flags are affected

- ◆ *Example:*

ORL A, R2

If ACC=D3H (11010011) and R2=75H (01110101), the result of the instruction is ACC=F7H (11110111)

- ◆ *Example:*

ORL P1, #11000010B

This instruction sets bits 7, 6, and 1 of output Port 1

XRL <dest-byte>,<source-byte>

- ◆ This instruction performs the logical XOR (Exclusive OR) operation on the source and destination operands and stores the result in the destination variable

- ◆ No flags are affected

- ◆ *Example:*

```
XRL    A,R0
```

If ACC=C3H (11000011) and R0=AAH (10101010), then the instruction results in ACC=69H (01101001)

- ◆ *Example:*

```
XRL    P1,#00110001
```

This instruction complements bits 5, 4, and 0 of output Port 1

CLR A and CPL A

CLR A

- ◆ This instruction clears the accumulator (all bits set to 0)
- ◆ No flags are affected
- ◆ If ACC=C3H, then the instruction results in ACC=00H

CPL A

- ◆ This instruction logically complements each bit of the accumulator (one's complement)
- ◆ No flags are affected
- ◆ If ACC=C3H (11000011), then the instruction results in ACC=3CH (00111100)

RL A

- ◆ The 8 bits in the accumulator are rotated one bit to the left. Bit 7 is rotated into the bit 0 position.
- ◆ No flags are affected
- ◆ If ACC=C3H (11000011), then the instruction results in ACC=87H (10000111) with the carry unaffected

RLC A

- ◆ The instruction rotates the accumulator contents one bit to the left through the carry flag
- ◆ Bit 7 of the accumulator will move into carry flag and the original value of the carry flag will move into the Bit 0 position
- ◆ No other flags are affected
- ◆ If ACC=C3H (11000011), and the carry flag is 1, the instruction results in ACC=87H (10000111) with the carry flag set

RR A

- ◆ The 8 bits in the accumulator are rotated one bit to the right. Bit 0 is rotated into the bit 7 position.
- ◆ No flags are affected
- ◆ If ACC=C3H (11000011), then the instruction results in ACC=E1H (11100001) with the carry unaffected

RRC A

- ◆ The instruction rotates the accumulator contents one bit to the right through the carry flag
- ◆ The original value of carry flag will move into Bit 7 of the accumulator and Bit 0 rotated into carry flag
- ◆ No other flags are affected
- ◆ If ACC=C3H (11000011), and the carry flag is 0, the instruction results in ACC=61H (01100001) with the carry flag set

SWAP A

- ◆ This instruction interchanges the low order 4-bit nibbles (A3-0) with the high order 4-bit nibbles (A7-4) of the ACC
- ◆ The operation can also be thought of as a 4-bit rotate instruction
- ◆ No flags are affected
- ◆ If ACC=C3H (11000011), then the instruction leaves ACC=3CH (00111100)

Data Transfer Instructions

- ◆ Data transfer instructions can be used to transfer data between an internal RAM location and SFR location without going through the accumulator
- ◆ It is possible to transfer data between the internal and external RAM by using indirect addressing
- ◆ The upper 128 bytes of data RAM are accessed only by indirect addressing and the SFRs are accessed only by direct addressing

Data Transfer Instructions

Mnemonic	Description
MOV @Ri, direct	[@Ri] = [direct]
MOV @Ri, #data	[@Ri] = immediate data
MOV DPTR, #data 16	[DPTR] = immediate data
MOVC A, @A+DPTR	A = Code byte from [@A+DPTR]
MOVC A, @A+PC	A = Code byte from [@A+PC]
MOVX A, @Ri	A = Data byte from external ram [@Ri]
MOVX A, @DPTR	A = Data byte from external ram [@DPTR]
MOVX @Ri, A	External[@Ri] = A
MOVX @DPTR, A	External[@DPTR] = A
PUSH direct	Push into stack
POP direct	Pop from stack
XCH A, Rn	A = [Rn], [Rn] = A
XCH A, direct	A = [direct], [direct] = A
XCH A, @Ri	A = [@Rn], [@Rn] = A
XCHD A, @Ri	Exchange low order digits

MOV <dest-byte>, <source-byte>

- ◆ This instruction moves the source byte into the destination location
- ◆ The source byte is not affected, neither are any other registers or flags
- ◆ *Example:*

```
MOV    R1, #60        ;R1=60H
MOV    A, @R1         ;A=[ 60H]
MOV    R2, #61        ;R2=61H
ADD    A, @R2         ;A=A+ [ 61H]
MOV    R7, A          ;R7=A
```

- ◆ If internal RAM locations 60H=10H, and 61H=20H, then after the operations of the above instructions R7=A=30H. The data contents of memory locations 60H and 61H remain intact.

MOV DPTR, #data 16

- ◆ This instruction loads the data pointer with the 16-bit constant and no flags are affected

- ◆ *Example:*

```
MOV    DPTR, #1032
```

- ◆ This instruction loads the value 1032H into the data pointer, i.e. DPH=10H and DPL=32H.

MOVC A,@A + <base-reg>

- ◆ This instruction moves a code byte from program memory into ACC
- ◆ The effective address of the byte fetched is formed by adding the original 8-bit accumulator contents and the contents of the base register, which is either the data pointer (DPTR) or program counter (PC)
- ◆ 16-bit addition is performed and no flags are affected
- ◆ The instruction is useful in reading the look-up tables in the program memory
- ◆ If the PC is used, it is incremented to the address of the following instruction before being added to the ACC
- ◆ *Example:*

```

                CLR    A
LOC1:           INC    A
                MOVC   A,@A + PC
                RET
Look_up        DB     10H
                DB     20H
                DB     30H
                DB     40H
```

- ◆ The subroutine takes the value in the accumulator to 1 of 4 values defined by the DB (define byte) directive
- ◆ After the operation of the subroutine it returns ACC=20H

MOVX <dest-byte>,<source-byte>

- ◆ This instruction transfers data between ACC and a byte of external data memory
- ◆ There are two forms of this instruction, the only difference between them is whether to use an 8-bit or 16-bit indirect addressing mode to access the external data RAM
- ◆ The 8-bit form of the MOVX instruction uses the EMI0CN SFR to determine the upper 8 bits of the effective address to be accessed and the contents of R0 or R1 to determine the lower 8 bits of the effective address to be accessed

- ◆ *Example:*

```
MOV      EMI0CN, #10H      ;Load high byte of
                           ;address into EMI0CN.
MOV      R0, #34H         ;Load low byte of
                           ;address into R0(or R1).
MOVX     A, @R0           ;Load contents of 1034H
                           ;into ACC.
```

MOVX <dest-byte>,<source-byte>

- ◆ The 16-bit form of the MOVX instruction accesses the memory location pointed to by the contents of the DPTR register

- ◆ *Example:*

```
MOV    DPTR,#1034H ;Load DPTR with 16 bit  
                        ;address to read (1034H).  
MOVX   A,@DPTR    ;Load contents of 1034H  
                        ;into ACC.
```

- ◆ The above example uses the 16-bit immediate MOV DPTR instruction to set the contents of DPTR
- ◆ Alternately, the DPTR can be accessed through the SFR registers DPH, which contains the upper 8 bits of DPTR, and DPL, which contains the lower 8 bits of DPTR

PUSH Direct

- ◆ This instruction increments the stack pointer (SP) by 1
- ◆ The contents of *Direct*, which is an internal memory location or a SFR, are copied into the internal RAM location addressed by the stack pointer
- ◆ No flags are affected

- ◆ *Example:*

PUSH 22H

PUSH 23H

- ◆ Initially the SP points to memory location 4FH and the contents of memory locations 22H and 23H are 11H and 12H respectively. After the above instructions, SP=51H, and the internal RAM locations 50H and 51H will store 11H and 12H respectively.

POP Direct

- ◆ This instruction reads the contents of the internal RAM location addressed by the stack pointer (SP) and decrements the stack pointer by 1. The data read is then transferred to the *Direct* address which is an internal memory or a SFR. No flags are affected.

- ◆ *Example:*

```
POP    DPH
POP    DPL
```

- ◆ If SP=51H originally and internal RAM locations 4FH, 50H and 51H contain the values 30H, 11H and 12H respectively, the instructions above leave SP=4FH and DPTR=1211H

```
POP    SP
```

- ◆ If the above line of instruction follows, then SP=30H. In this case, SP is decremented to 4EH before being loaded with the value popped (30H)

XCH A,<byte>

- ◆ This instruction swaps the contents of ACC with the contents of the indicated data byte

- ◆ *Example:*

XCH A,@R0

- ◆ Suppose R0=2EH, ACC=F3H (11110011) and internal RAM location 2EH=76H (01110110). The result of the above instruction leaves RAM location 2EH=F3H and ACC=76H.

XCHD A,@Ri

- ◆ This instruction exchanges the low order nibble of ACC (bits 0-3), with that of the internal RAM location pointed to by Ri register
- ◆ The high order nibbles (bits 7-4) of both the registers remain the same
- ◆ No flags are affected
- ◆ Example:

XCHD A,@R0

If R0=2EH, ACC=76H (01110110) and internal RAM location 2EH=F3H (11110011), the result of the instruction leaves RAM location 2EH=F6H (11110110) and ACC=73H (01110011)

Boolean Variable Instructions

- ◆ The 8051 processor can perform single bit operations
- ◆ The operations include *set*, *clear*, as well as *and*, *or* and *complement* instructions
- ◆ Also included are bit-level moves or conditional jump instructions
- ◆ All bit accesses use direct addressing

Mnemonic	Description
CLR C	Clear C
CLR bit	Clear direct bit
SETB C	Set C
SETB bit	Set direct bit
CPL C	Complement c
CPL bit	Complement direct bit
ANL C,bit	AND bit with C
ANL C,/bit	AND NOT bit with C
ORL C,bit	OR bit with C
ORL C,/bit	OR NOT bit with C
MOV C,bit	MOV bit to C
MOV bit,C	MOV C to bit
JC rel	Jump if C set
JNC rel	Jump if C not set
JB bit,rel	Jump if specified bit set
JNB bit,rel	Jump if specified bit not set
JBC bit,rel	if specified bit set then clear it and jump

CLR <bit>

- ◆ This operation clears (reset to 0) the specified bit indicated in the instruction
- ◆ No other flags are affected
- ◆ CLR instruction can operate on the carry flag or any directly-addressable bit
- ◆ *Example:*

CLR P2.7

If Port 2 has been previously written with DCH (11011100), then the operation leaves the port set to 5CH (01011100)

SETB <bit>

- ◆ This operation sets the specified bit to 1
- ◆ SETB instruction can operate on the carry flag or any directly-addressable bit
- ◆ No other flags are affected
- ◆ *Example:*
 - SETB C**
 - SETB P2.0**
- ◆ If the carry flag is cleared and the output Port 2 has the value of 24H (00100100), then the result of the instructions sets the carry flag to 1 and changes the Port 2 value to 25H (00100101)

CPL <bit>

- ◆ This operation complements the bit indicated by the operand
- ◆ No other flags are affected
- ◆ CPL instruction can operate on the carry flag or any directly-addressable bit
- ◆ *Example:*
 - CPL P2.1**
 - CPL P2.2**
- ◆ If Port 2 has the value of 53H (01010011) before the start of the instructions, then after the execution of the instructions it leaves the port set to 55H (01010101)

ANL C, <source-bit>

- ◆ This instruction ANDs the bit addressed with the Carry bit and stores the result in the Carry bit itself
- ◆ If the source bit is a logical 0, then the instruction clears the carry flag; else the carry flag is left in its original value
- ◆ If a slash (/) is used in the source operand bit, it means that the logical complement of the addressed source bit is used, **but the source bit itself is not affected**
- ◆ No other flags are affected

- ◆ *Example:*

```
MOV    C,P2.0      ;Load C with input pin
                    ;state of P2.0.
ANL    C,P2.7      ;AND carry flag with
                    ;bit 7 of P2.
MOV    P2.1,C      ;Move C to bit 1 of Port 2.
ANL    C,/OV       ;AND with inverse of OV flag.
```

- ◆ If P2.0=1, P2.7=0 and OV=0 initially, then after the above instructions, P2.1=0, CY=0 and the OV remains unchanged, i.e. OV=0

ORL C, <source-bit>

- ◆ This instruction ORs the bit addressed with the Carry bit and stores the result in the Carry bit itself
- ◆ It sets the carry flag if the source bit is a logical 1; else the carry is left in its original value
- ◆ If a slash (/) is used in the source operand bit, it means that the logical complement of the addressed source bit is used, **but the source bit itself is not affected**
- ◆ No other flags are affected

- ◆ *Example:*

```
MOV    C,P2.0      ;Load C with input pin
                    ;state of P2.0.
ORL    C,P2.7      ;OR carry flag with
                    ;bit 7 of P2.
MOV    P2.1,C      ;Move C to bit 1 of
                    ;port 2.
ORL    C,/OV       ;OR with inverse of OV
                    ;flag.
```

MOV <dest-bit>,<source-bit>

- ◆ The instruction loads the value of source operand bit into the destination operand bit
- ◆ One of the operands **must** be the carry flag; the other may be any directly-addressable bit
- ◆ No other register or flag is affected

- ◆ *Example:*

```
MOV    P2.3,C
```

```
MOV    C,P3.3
```

```
MOV    P2.0,C
```

- ◆ If P2=C5H (11000101), P3.3=0 and CY=1 initially, then after the above instructions, P2=CCH (11001100) and CY=0.

JC rel

- ◆ This instruction branches to the address, indicated by the label, if the carry flag is set, otherwise the program continues to the next instruction

- ◆ No flags are affected

- ◆ *Example:*

```
CLR    C
SUBB   A,R0
JC     ARRAY1
MOV    A,#20H
```

- ◆ The carry flag is cleared initially. After the SUBB instruction, if the value of A is smaller than R0, then the instruction sets the carry flag and causes program execution to branch to ARRAY1 address, otherwise it continues to the MOV instruction.

JNC rel

- ◆ This instruction branches to the address, indicated by the label, if the carry flag is **not** set, otherwise the program continues to the next instruction
- ◆ No flags are affected. **The carry flag is not modified.**

- ◆ *Example:*

```
CLR    C
SUBB   A,R0
JNC    ARRAY2
MOV    A,#20H
```

- ◆ The above sequence of instructions will cause the jump to be taken if the value of A is greater than or equal to R0. Otherwise the program will continue to the MOV instruction.

JB <bit>,rel

- ◆ This instruction jumps to the address indicated if the destination bit is 1, otherwise the program continues to the next instruction
- ◆ No flags are affected. **The bit tested is not modified.**
- ◆ *Example:*

```
JB ACC.7,ARRAY1
JB P1.2,ARRAY2
```
- ◆ If the accumulator value is 01001010 and Port 1=57H (01010111), then the above instruction sequence will cause the program to branch to the instruction at ARRAY2

JNB <bit>,rel

- ◆ This instruction jumps to the address indicated if the destination bit is 0, otherwise the program continues to the next instruction
- ◆ No flags are affected. **The bit tested is not modified.**
- ◆ *Example:*

```
JNB ACC.6,ARRAY1  
JNB P1.3,ARRAY2
```
- ◆ If the accumulator value is 01001010 and Port 1=57H (01010111), then the above instruction sequence will cause the program to branch to the instruction at ARRAY2

JBC <bit>,rel

- ◆ If the source bit is 1, this instruction clears it and branches to the address indicated; else it proceeds with the next instruction
- ◆ **The bit is not cleared if it is already a 0.** No flags are affected.
- ◆ *Example:*
 - JBC P1.3,ARRAY1**
 - JBC P1.2,ARRAY2**
- ◆ If P1=56H (01010110), the above instruction sequence will cause the program to branch to the instruction at ARRAY2, modifying P1 to 52H (01010010)

Program Branching Instructions

- ◆ Program branching instructions are used to control the flow of actions in a program
- ◆ Some instructions provide decision making capabilities and transfer control to other parts of the program, e.g. conditional and unconditional branches

Mnemonic	Description
ACALL addr11	Absolute subroutine call
LCALL addr16	Long subroutine call
RET	Return from subroutine
RETI	Return from interrupt
AJMP addr11	Absolute jump
LJMP addr16	Long jump
SJMP rel	Short jump
JMP @A+DPTR	Jump indirect
JZ rel	Jump if A=0
JNZ rel	Jump if A NOT=0
CJNE A,direct,rel	Compare and Jump if Not Equal
CJNE A,#data,rel	
CJNE Rn,#data,rel	
CJNE @Ri,#data,rel	
DJNZ Rn,rel	Decrement and Jump if Not Zero
DJNZ direct,rel	
NOP	No Operation

ACALL addr11

- ◆ This instruction **unconditionally** calls a subroutine indicated by the address
- ◆ The operation will cause the PC to increase by 2, then it pushes the 16-bit PC value onto the stack (low order byte first) and increments the stack pointer twice
- ◆ The PC is now loaded with the value *addr11* and the program execution continues from this new location
- ◆ The subroutine called must therefore start within the same 2 kB block of the program memory

- ◆ No flags are affected

- ◆ *Example:*
 - ◆ **ACALL LOC_SUB**

- ◆ If SP=07H initially and the label “LOC_SUB” is at program memory location 0567H, then executing the instruction at location 0230H, SP=09H, internal RAM locations 08H and 09H will contain 32H and 02H respectively and PC=0567H

LCALL *addr16*

- ◆ This instruction calls a subroutine located at the indicated address
- ◆ The operation will cause the PC to increase by 3, then it pushes the 16-bit PC value onto the stack (low order byte first) and increments the stack pointer twice
- ◆ The PC is then loaded with the value *addr16* and the program execution continues from this new location
- ◆ Since it is a Long call, the subroutine may therefore begin anywhere in the full 64 kB program memory address space
- ◆ No flags are affected
- ◆ *Example:*
LCALL LOC_SUB
- ◆ Initially, SP=07H and the label “LOC_SUB” is at program memory location 2034H. Executing the instruction at location 0230H, SP=09H, internal RAM locations 08H and 09H contain 33H and 02H respectively and PC=2034H

RET

- ◆ This instruction returns the program from a subroutine
- ◆ RET pops the high byte and low byte address of PC from the stack and decrements the SP by 2
- ◆ The execution of the instruction will result in the program to resume from the location just after the “call” instruction
- ◆ No flags are affected
- ◆ Suppose SP=0BH originally and internal RAM locations 0AH and 0BH contain the values 30H and 02H respectively. The instruction leaves SP=09H and program execution will continue at location 0230H

RETI

- ◆ This instruction returns the program from an interrupt subroutine
- ◆ RETI pops the high byte and low byte address of PC from the stack and restores the interrupt logic to accept additional interrupts
- ◆ SP decrements by 2 and no other registers are affected. However the PSW is not automatically restored to its pre-interrupt status
- ◆ After the RETI, program execution will resume immediately after the point at which the interrupt is detected
- ◆ Suppose SP=0BH originally and an interrupt is detected during the instruction ending at location 0213H
 - Internal RAM locations 0AH and 0BH contain the values 14H and 02H respectively
 - The RETI instruction leaves SP=09H and returns program execution to location 0234H

AJMP addr11

- ◆ The AJMP instruction transfers program execution to the destination address which is located at the absolute short range distance (short range means 11-bit address)
- ◆ The destination must therefore be within the same 2kB block of program memory
- ◆ *Example:*
AJMP NEAR
- ◆ If the label NEAR is at program memory location 0120H, the AJMP instruction at location 0234H loads the PC with 0120H

LJMP addr16

- ◆ The LJMP instruction transfers program execution to the destination address which is located at the absolute long range distance (long range means 16-bit address)
- ◆ The destination may therefore be anywhere in the full 64 kB program memory address space
- ◆ No flags are affected
- ◆ *Example:*

```
LJMP FAR_ADR
```
- ◆ If the label FAR_ADR is at program memory location 3456H, the LJMP instruction at location 0120H loads the PC with 3456H

SJMP rel

- ◆ This is a short jump instruction, which increments the PC by 2 and then adds the relative value '*rel*' (signed 8-bit) to the PC
- ◆ This will be the new address where the program would branch to unconditionally
- ◆ Therefore, the range of destination allowed is from -128 to +127 bytes from the instruction
- ◆ *Example:*
SJMP RELSRT
- ◆ If the label RELSRT is at program memory location 0120H and the SJMP instruction is located at address 0100H, after executing the instruction, PC=0120H.

JMP @A + DPTR

- ◆ This instruction adds the 8-bit unsigned value of the ACC to the 16-bit data pointer and the resulting sum is returned to the PC
- ◆ Neither ACC nor DPTR is altered
- ◆ No flags are affected

- ◆ *Example:*

```
                MOV    DPTR, #LOOK_TBL
                JMP    @A + DPTR
LOOK_TBL:      AJMP   LOC0
                AJMP   LOC1
                AJMP   LOC2
```

If the ACC=02H, execution jumps to LOC1

- ◆ AJMP is a two byte instruction

JZ rel

- ◆ This instruction branches to the destination address if ACC=0; else the program continues to the next instruction
- ◆ The ACC is not modified and no flags are affected

- ◆ *Example:*

```
SUBB A,#20H  
JZ    LABEL1  
DEC   A
```

- ◆ If ACC originally holds 20H and CY=0, then the SUBB instruction changes ACC to 00H and causes the program execution to continue at the instruction identified by LABEL1; otherwise the program continues to the DEC instruction

JNZ rel

- ◆ This instruction branches to the destination address if any bit of ACC is a 1; else the program continues to the next instruction
- ◆ The ACC is not modified and no flags are affected

- ◆ *Example:*

```
DEC    A
JNZ    LABEL2
MOV    RO, A
```

- ◆ If ACC originally holds 00H, then the instructions change ACC to FFH and cause the program execution to continue at the instruction identified by LABEL2; otherwise the program continues to MOV instruction

CJNE <dest-byte>, <source-byte>, rel

- ◆ This instruction compares the magnitude of the *dest-byte* and the *source-byte* and branches if their values are not equal
- ◆ The carry flag is set if the unsigned *dest-byte* is less than the unsigned integer *source-byte*; otherwise, the carry flag is cleared
- ◆ Neither operand is affected
- ◆ *Example:*

```
CJNE    R3, #50H, NEQU
        ... ..
NEQU:   JC     LOC1
        ... ..
LOC1:   ... ..
```

;R3 = 50H
;If R3 < 50H
;R7 > 50H
;R3 < 50H

DJNZ <byte>, <rel-addr>

- ◆ This instruction is "decrement jump not zero"
- ◆ It decrements the contents of the destination location and if the resulting value is not 0, branches to the address indicated by the source operand
- ◆ An original value of 00H underflows to FFH
- ◆ No flags are affected

- ◆ *Example:*

DJNZ 20H, LOC1

DJNZ 30H, LOC2

DJNZ 40H, LOC3

- ◆ If internal RAM locations 20H, 30H and 40H contain the values 01H, 5FH and 16H respectively, the above instruction sequence will cause a jump to the instruction at LOC2, with the values 00H, 5EH, and 15H in the 3 RAM locations.
 - Note, the first instruction will not branch to LOC1 because the [20H] = 00H, hence the program continues to the second instruction
 - Only after the execution of the second instruction (where the location [30H] = 5FH), then the branching takes place

NOP

- ◆ This is the no operation instruction
- ◆ The instruction takes one machine cycle operation time
- ◆ Hence it is useful to time the ON/OFF bit of an output port
- ◆ *Example:*

CLR P1.2

NOP

NOP

NOP

NOP

SETB P1.2

- ◆ The above sequence of instructions outputs a low-going output pulse on bit 2 of Port 1 lasting exactly 5 cycles.
 - Note a simple SETB/CLR generates a 1 cycle pulse, so four additional cycles must be inserted in order to have a 5-clock pulse width

Thanks to www.silabs.com/MCU